

Concealed thermostatic shower

2746607 / 2746609 / 2746616 / 2746643 / 2746645 / 2746651

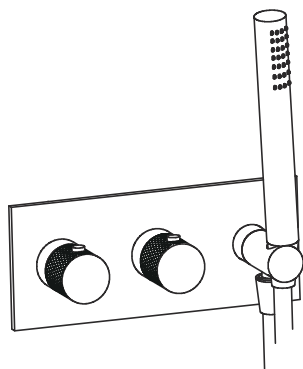
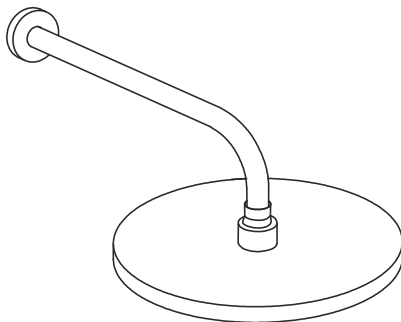

INSTALLATION INSTRUCTIONS

INTRODUCTION

Please read these instructions carefully and keep in a safe place for future reference.

General Installation Requirements.

The installation must comply with regulations of the Local Water Authority as contained in their bylaws. All of the taps in the range are single flow (the hot and cold water mix in the body) and should therefore be supplied with hot and cold water at balanced pressures, both from the tank or both from the mains (via a combination boiler for example). If the taps are not supplied at balanced pressures then the mixer will not function correctly. It will also be necessary to fit non-return valves on both hot and cold feeds. It is very important that all pipework is flushed thoroughly after installation to avoid damaging the ceramic discs.

WARNING

Before installing the new mixer it is essential that you thoroughly flush through the supply pipes in order to remove any remaining swarf, solder or other impurities. Failure to carry out this simple procedure could cause problems or damage to the working of the mixer.

These hints have been prepared for your guidance, you must exercise due care at all times. We do not take responsibility for any problems that may occur through incorrect installation.

GENERAL INSTALLATION

The thermostatic mixing valve has been specifically designed and manufactured to meet the requirements of EN1111. The valve has been independently tested and approved.

This mixer valve is suitable for any water system. Where instantaneous heaters are used, the flow of hot water sufficient to start and go on burning must reach the minimum flow required – as specified by the heater manufacturer.

These fittings are mixing devices and therefore water supplies must be reasonably balanced.

Please take great care when installing this mixer not to damage its surface. Operating pressures (on hot and cold line) should be kept as balanced as possible in order to assure optimum efficiency.

Note: When pressure is higher than 5 bar a pressure reducer is required to be fitted before the valve.

Please note if installing in an enclosed environment, access should be left for servicing and maintenance. No costs relating to inadequate access can be accepted.

GENERAL INSTALLATION

Working Parameters And Technical Specification

Factory Temperature Setting	38° C
Temperature Setting Range	35° C to 46° C
Temperature (Hot Supply)	55° C to 65° C
Temperature (Cold Supply)	5° C to 25° C
Minimum Hot To Mix Differential Temperature	10° C
Temperature Stability	±2° C
Working Pressure, Static	10 Bar Max
Working Pressure, Dynamic High Pressure	0.5–5 Bar

NOTES:

If water supply is fed by gravity then supply pressure should be verified to ensure the conditions of use are appropriate for the valve.

1:If there is a residual flow during the commissioning or the annual verification (cold water supply isolation test), then this is acceptable providing the temperature of the water seeping from the valve is no more than 2°C mixed water outlet temperature setting of the valve.

2:Temperature readings should be taken at the normal flow rate after allowing for the system to stabilize.

3:The sensing part of the thermometer probe must be fully submerged in the water that is to be tested.

INSTALLATION

Before installing the thermostatic shower valve, please make sure the correct way for inlet water, left for hot water, right for cold water, or the thermostatic shower valve will lose efficacy. The Thermostatic Mixing Valve contains temperature sensitive components. Soldering near the union adaptors or main valve body must be avoided. Rinse pipe work carefully for a long while before fitting the valve: do not allow dirt, metal particles or shavings to block the filters fitted on inlets. Turn off the water supply.

Warning! Please check for any hidden cables and pipes before drilling holes in the wall. Outlet 2 is an option as extra outlet which should be blocked with the plug that is included.

Note: The valve must be connected to rigid pipe work for support as there are no back nuts or fixing holes.

The shower head and hand shower can be changed to different model for different appearance.

Note: When pressure is higher than 5 bar a pressure reducer is required to be fitted before the valve.

Please note if installing in an enclosed environment, access should be left for servicing and maintenance. No costs relating to inadequate access can be accepted.

Note: When pressure is higher than 5 bar a pressure reducer is required to be fitted before the valve.

Please note if installing in an enclosed environment, access should be left for servicing and maintenance. No costs relating to inadequate access can be accepted.

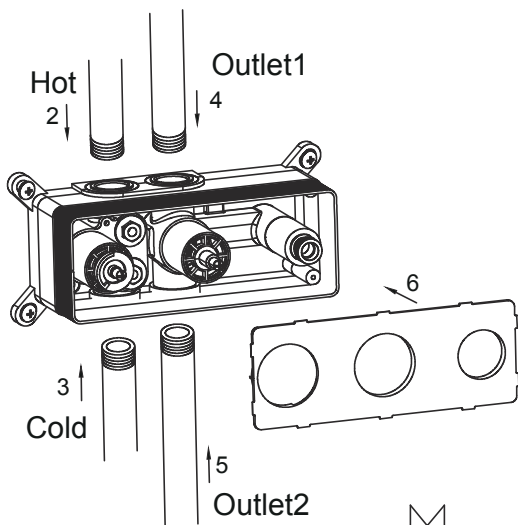
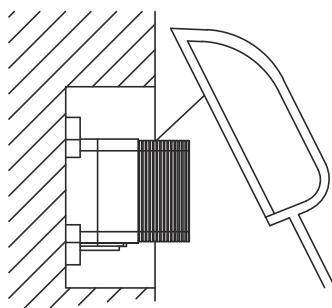
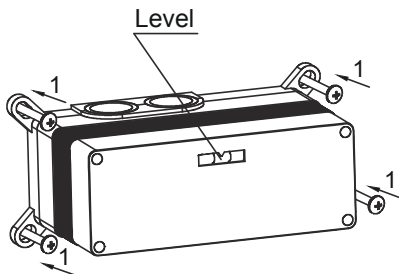
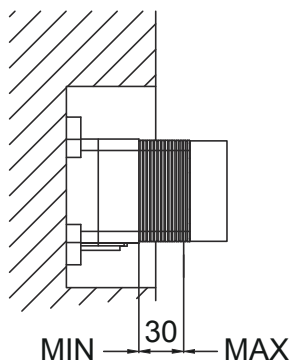

Extra outlet 2 optional

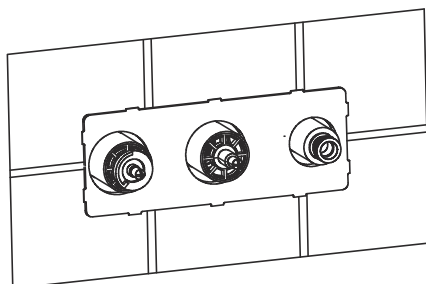

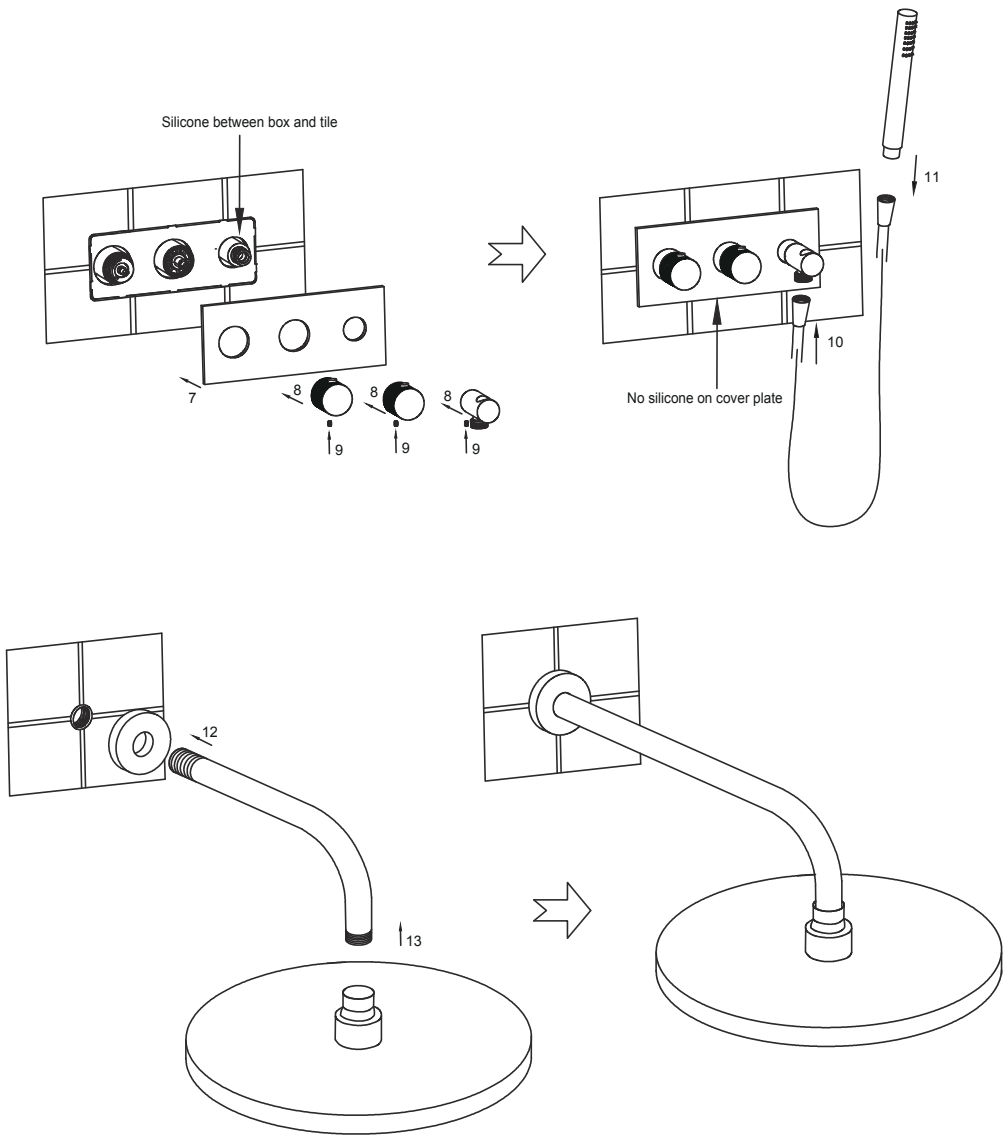

OPERATION SPECIFICATIONS

Hot Water Supply Temperature:

Maximum: 80° C (It will affect the thermostatic mixers' working life)

Minimum: 50° C

Advise: 55° C~65° C

Operating Pressure

Maximum:5bar Minimum: 0.2 bar

Recommended outlet temperatures

The following mixed water outlet temperature for use in all premises:

44° C for bath fill but see notes below; 41°C for showers;

The mixed water temperatures must never exceed 46° C.

The maximum mixed water temperature can be 2° C above the recommended maximum set outlet temperature.

Note:

46° C is the maximum mixed water temperature from the bath tap. The maximum temperature takes account of the allowable temperature tolerances inherent in thermostatic mixing valves and temperature losses in metal baths.

It is not a safe bathing temperature for adults or children.

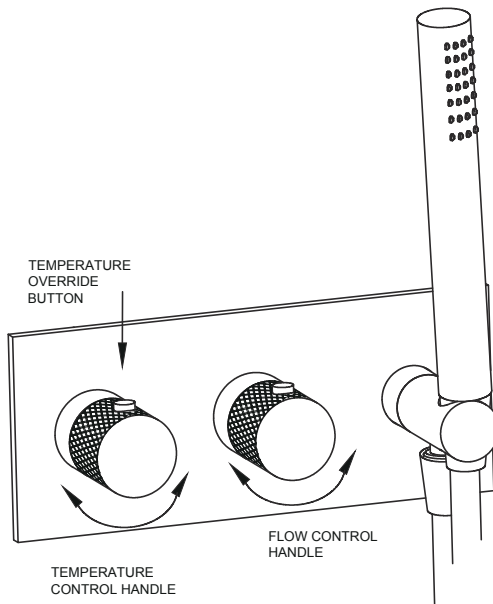

CARE OF THE MIXER

Our products are finished to the highest standard and due care needs to be taken to ensure their looks are retained.

We recommend cleaning all products with a soft damp cloth only and wax, advise strongly against the use of all cleaning products i.e. powders and liquids.

For the shower nipples please clean by your fingers.

If the above instructions are not followed this will invalidate your guarantee in the event of a problem occurring.

After cleaning, reassemble the thermostatic shower valve. Exercise, reset and test the valve as laid out in the commissioning section.

COMMISSIONING&TEMPERATURE RESETTING

Please ensure that the commissioning of the valve is done under normal operating conditions. The Thermostatic Mixing Valve is supplied factory set at 38° C. To alter this setting, proceed as follows.

Note: mix water temperature at terminal fitting should never exceed 46° C.

The valve has been factory set under balance pressures and hot water supply at 65° C. When your specific operating conditions are significantly different from the above, the temperature of the water may vary from the setting.

When the difference is too great, you can adjust the calibration of the valve to suit individual requirements of the installation:

1. Select 38° C or the arrow on the handle and check the temperature of the water being delivered to the outlet with a thermometer.

2. If the temperature is unacceptable proceed to reset the calibration as follows:

Remove the temperature control handle by prizing off the screw cover, removing the screw and pulling off the handle (do not remove the plastic stop ring).

Turn the spline of the valve clockwise to decrease the temperature and anti-clockwise to increase the temperature until 38° is achieved.

3. Ensure that the stop on the stop ring is at 12 o'clock and replace the handle with the temperature override button also pointing at 12 o'clock being careful not to turn the spline of the valve. The valve setting is now calibrated to suit your requirements.

A digital hand-held thermometer should be used to measure the outlet temperature correctly which must not exceed 38° C.

Once the correct outlet temperature has been achieved, the valves internal mechanism should be exercised at least three times by alternately isolating the hot and cold supplies.

This will cause the piston to travel its full stroke and will ensure that the valve is operating correctly. If the set temperature has drifted after this operation, then the commissioning operation should be repeated.

COMMISSIONING&TEMPERATURE RESETTING

Once the valve has been commissioned, a fail-safe shut off test should be performed. Isolate the cold supply. The flow should reduce to a trickle within a couple of seconds depending on site conditions.

If the temperature has not altered, repeat the test for the hot supply. If either fail-safe function does not operate, ensure that supply pressures and temperatures are within the valves normal operating parameters. In addition, check that the hot supply temperature is at least 10° C above the valves set mixed outlet temperature, i.e. hot to mix differential temperature.

If this is not the case, then the valve will be slow to shut down on cold water failure.

For optimum performance, it is recommended that the dynamic pressures be as close as equal as possible. If the dynamic pressures are outside a 10:1 ratio, then a pressure reducing valve should be fitted to the higher supply pressure or, if preferred, the lower supply pressure boosted

MAINTENANCE OF THE MIXER

The thermostatic shower valve should be tested against the original performance results once a year after installation. When testing is due the following performance checks shall be carried out.

Performance checks that should be carried out at routine maintenance times are:

- Measure the mixed water temperature at the outlet.
- Carry out the cold fail-safe shut off tests by isolating the cold water supply to the TMV; wait for five seconds, if the water is still flowing check that the temperature is below 46° C.
- If there is no significant change to the set outlet temperature (2° C or less change from the original settings) and the fail-safe shut off is functioning, then the valve is working correctly and no further service work is required.

Filters.

This thermostatic valve is fitted with a double filtering facility. Filters are fitted on the water inlets and on the thermostatic cartridge.

Depending on the water quality, filters may become dirty, causing reduced flow and inefficient working of the valve.

Shut off the water supply to both inlets at the isolating valves.

Inlet Filters.

Undo both locking nuts at the back of the valve and remove from the wall. Pull out the filter/washer, rinse in water to remove the dirt, and then soak them in vinegar or descaling agent.

MAINTENANCE OF THE MIXER

Cartridge Filters

To clean the filters, you must first remove the cartridge from the housing. Removing the Cartridge

- 1.Remove the handle (see temperature resetting).
- 2.Unscrew the grub screw on the underside of the body and pull out the cartridge.
- 3.Clean the filters by rinsing them in water to remove the dirt and soaking them in vinegar or descaling agent.
- 4.Before reassembling the cartridge, clean its housing with a wet cloth and grease the 'O' rings on the cartridge.
- 5.Reassemble the cartridge into the body aligning up the hole in the cartridge with the grub screw, then place the plastic stop ring onto the cartridge with the stop at 12 o'clock position.
- 6.Make sure everything is tight and secure and turn on the water supply at the isolating valves.
- 7.Now check the water temperature to ensure you are happy with it.
- 8.Ensure that the stop on the stop ring is at 12 o'clock and replace the handle with the temperature override button also pointing at 12 o'clock being careful not to turn the spline of the valve.
- 9.Replace the handle.

MAINTENANCE OF THE MIXER

